

Optimization and Enhancement of Load Carrying Capacity of CNC Coordinate Drilling Machine using Finite Element Method

N. Ashwin Kumar¹, Basava Raju Pondhe²

¹(B.Tech in Mechanical with Specialization in Energy Engineering, VIT University, Vellore, India)

²(Joint General Manager, HMT Machine Tools Limited, Bangalore, India)

Abstract— The CNC Co-Ordinate Drilling machine indigenously designed and manufactured by HMT Machine Tools Ltd is capable of withstanding a load carrying capacity of 8000 kg. In order to meet the demand for the same machine with a higher load carrying capacity of 14000 kg the CNC Co-Ordinate Drilling machine was modified. The objective of this industrial project is to carry out analysis and to validate the actual load carrying capacity of the original design of machine bed and the new design proposed by the company, using finite element analysis. As a part of analysis for this project an optimized design of the bed was suggested by the author to endure the load carrying capacity of 14000 kg. Analysis was carried out on the bed of the machine where additional ribs were added to the bed in order to withstand higher capacity. The software's used include Solid Works premium 2012 for modeling and ANSYS 14.5 to carry out finite element analysis. Three stages of FEA were carried out, that is for the original bed and the bed redesigned by the company followed by the optimized bed designed by the author. The optimized design generated during the project is also capable of withstanding 14000 kg by reorientation of the ribbing pattern at appropriate locations. Resulting in reduction of weight by 800 kg and approximately a sum of INR 100000 rupees can be saved.

1 INTRODUCTION

The CNC Coordinate drilling machine is a bridge type double column with a moving arm designed for drilling, tapping, milling, and rough boring operations. It is ideally suited for heavy and bulky components and tube sheet drilling. The machine consists of bed, column, spindle head, table assembly and electrical components. The salient features of this machine includes large work area, linear motion anti friction guide ways for table slider for X axis whereas hardened and ground guide ways coated with Turcite facilitate the motion along Y and Z axis and preloaded precision ball screw for X, Y, Z, W axis. The CNC system is empowered with AC Servo motors which facilitate the movements about the 4 axis. Apart from having power tool clamping, the spindle is supported on a set of precision angular contact ball bearings.

Coordinate drilling machines are intensively used for machining purpose in tool rooms. The operations such as drilling, tapping, milling and rough boring are the primary operations used to carry out machining in the industrial sector. Reducing the weight of such machine would make it easier for transportation, maintenance also reduce the cost of manufacturing of the machine.

Analysis plays a major role in optimization. To enhance the load carrying capacity of this machine, modifications were carried out in the bed, work table and the ball screw of the machine. The major structural modifications were carried out in the machine bed which was created by welding Mild Steel plates together. The reorientation of the ribbing pattern led to the increase in the load carrying capacity. Three stages of finite element analysis were carried out in the course of the project.

The first set of analysis was carried out on the bed originally designed by the company to withstand a load carrying capacity of 8000 kg; the original bed is designated as BED1.0. The second analysis was carried out on the bed redesigned by the company for a load capacity of 14000 kg this bed is designated as BED 2.0. The third set of analysis was carried out on the optimized bed designed by the author. The optimized bed designed by the author is designated as BED 3.0.

2 EXPERIMENTAL PROGRAM

2.1 Material Properties

The bed is made by assembling Mild Steel plates of various thicknesses by the process of welding. For all the 3 beds namely BED 1.0, 2.0, 3.0 the same material is used. The properties of Mild Steel are mentioned in table 1. The steel used complies with the HMT standards. The composition, scope, applications, and requirements of the material complies with IS 2062:2006, IS 1852:1985 standards.

Table 1: Physical Properties of mild steel

Sl No.	Property	Value
1.	Density	7861.093 kg/m ³
2.	Young's Modulus	210000 MPa
3.	Poissons ratio	0.3
4.	Bulk Modulus	175000 MPa
5.	Shear Modulus	80769 MPa
6.	Yield Strength	370.25 MPa
7.	Ultimate Tensile Strength	439 MPa
8.	Elongation	15%
9.	Rockwell Hardness	B71

2.2 BED 1.0

The original bed designed by HMT initially to withstand a load carrying capacity of 8000 kg is designated as BED 1.0 this bed is made by welding Mild Steel plates of varying thickness in a criss-cross pattern. 23 types of Mild steel plates are used to create the original bed. The weight of BED 1.0 sums up to 11000 kg. Drawing-1 & 2 represents the Solid Works drawing of BED 1.0 in the 2D format. The geometry of BED 1.0 is shown in fig 1.

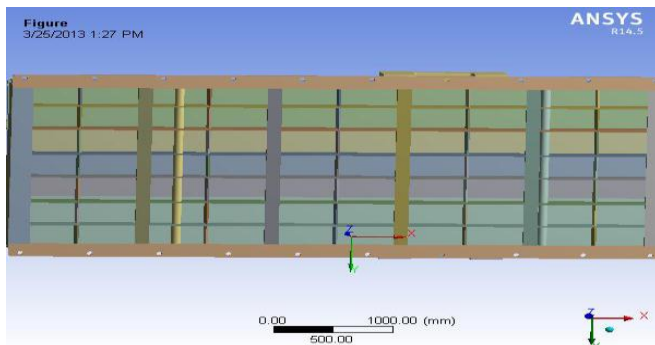

Fig 1: Geometry of BED 1.0

2.3 BED 2.0

The BED 1.0 re-designed by HMT in order to withstand a higher load carrying capacity of 14000 kg is designated as BED 2.0. This bed is made by welding additional 4 new types of Mild Steel plates to the Original BED 1.0. The 4 new plates created are used to form additional ribs and hence enhance the strength of the structure. The new plates are placed in between the old ribs. Another salient feature about this design is that it has another set of leveling screws along with foundation bolts which are aligned on either sides of the central axis of the machine. By introducing an additional set of leveling screws which are attached to 40 mm thick plates the equilibrium and support of the structure increases to a great extent. The additional ribs added weigh 1107 kg. Hence the overall weight of BED 2.0 is 12107 kg. Drawing 3 represents the Solid Works drawing of BED 2.0 in the 2D format. The geometry of BED 2.0 is shown in fig 2.

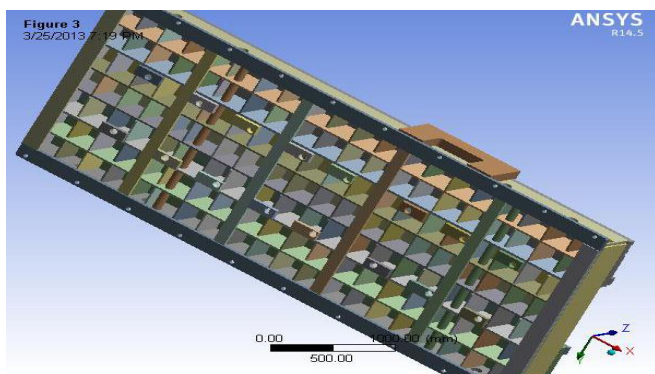

Fig 2: Geometry of BED 2.0

2.4 BED 3.0

The optimized design of bed is also designed to withstand a load carrying capacity of 14000 kg is designated as BED 3.0. This bed is made by welding an additional 2 new Mild Steel plates of varying thickness to the Original BED 1.0. The concept of purlin structure is introduced in this design which enhances high load carrying capacity with a limited quantity of material used.

The additional ribs added to the BED 1.0 accounts only to 320 kg and the overall weight of BED 3.0 is 11320 kg which saves up to 787 kg of Mild Steel over BED 2.0. Due to the concept of Purlin structure a considerable amount of weight is reduced for the same required effect. Drawing 4 represents the Solid Works drawing of BED 3.0 in the 2D format. The geometry of BED 3.0 is shown in fig 3.

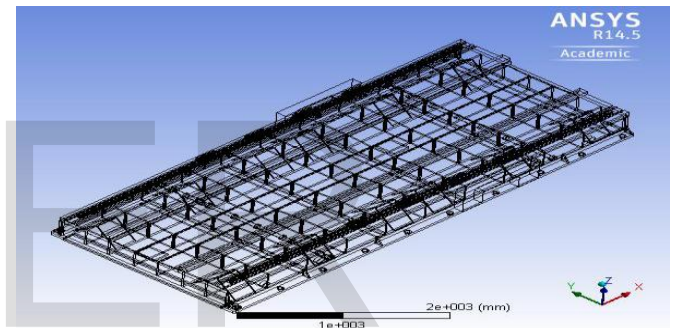
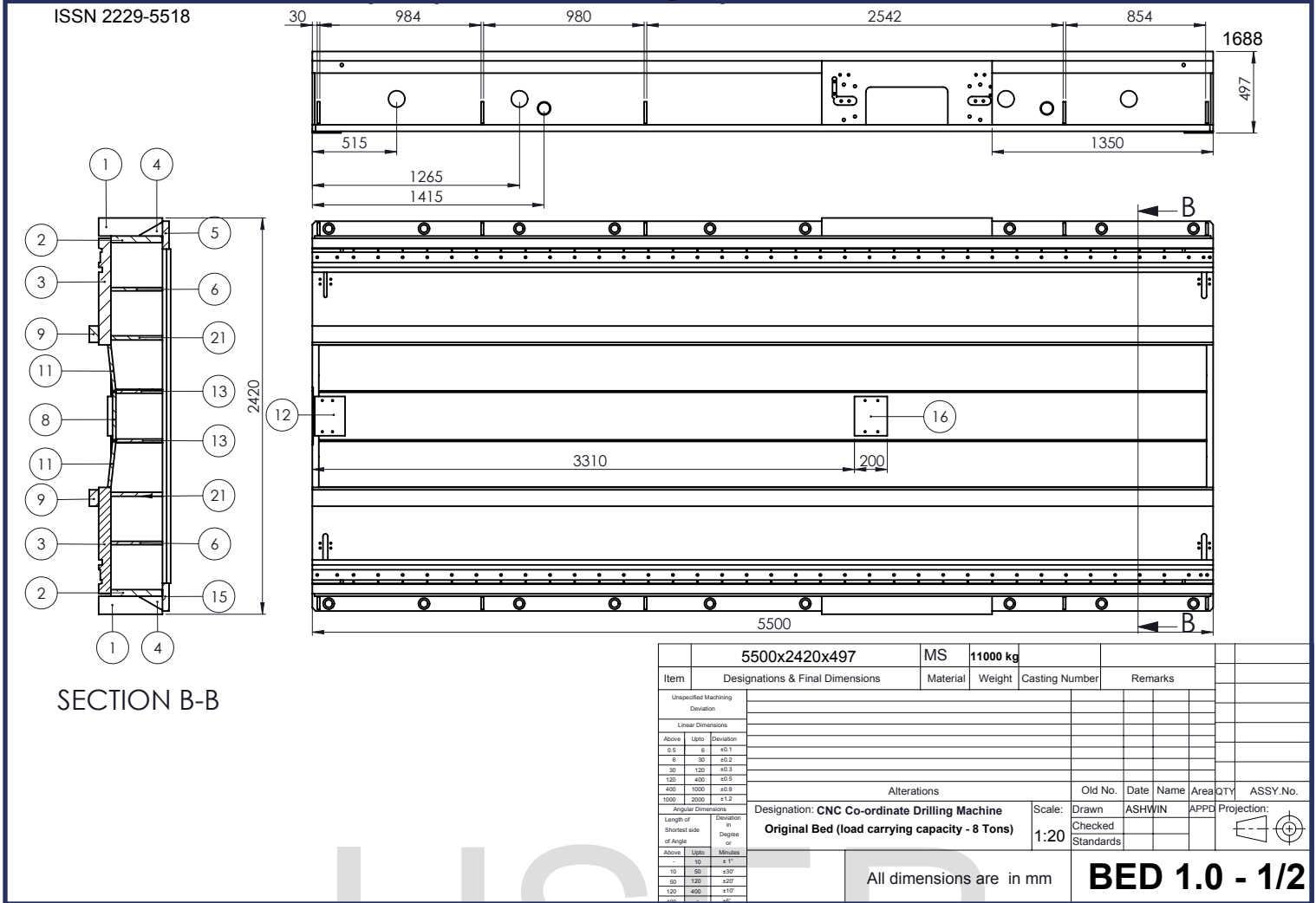

Fig 3: Geometry of BED 3.0 (wire mesh view)

2.4.1 Concept of Purlins

The principal function of roofing purlins is to transfer the forces on the roof of a building to its main structure. The wall rails perform the same role on the facades. Purlins and wall rails are important components in the secondary structure of a building. It should be noted that, in a large number of steel-frame buildings, with a single ground floor, the weight of the purlins and wall rails constitutes an important element in terms of the overall weight of the structure (15 to 20%); failure to optimize on this could lead to a deal being lost in a highly competitive situation. The purlin structure of a building is designed in accordance with the type of roofing to be used.

The concept of Purlins is very famous for building's roof tops. The same Purlin concept of distributing the load to the main structure is applied in order to attain an optimized design without any compromise in the load carrying capacity. By implementing this design the Purlin structure gets a new application in the field of Machine Tool Building.



Drawing 2

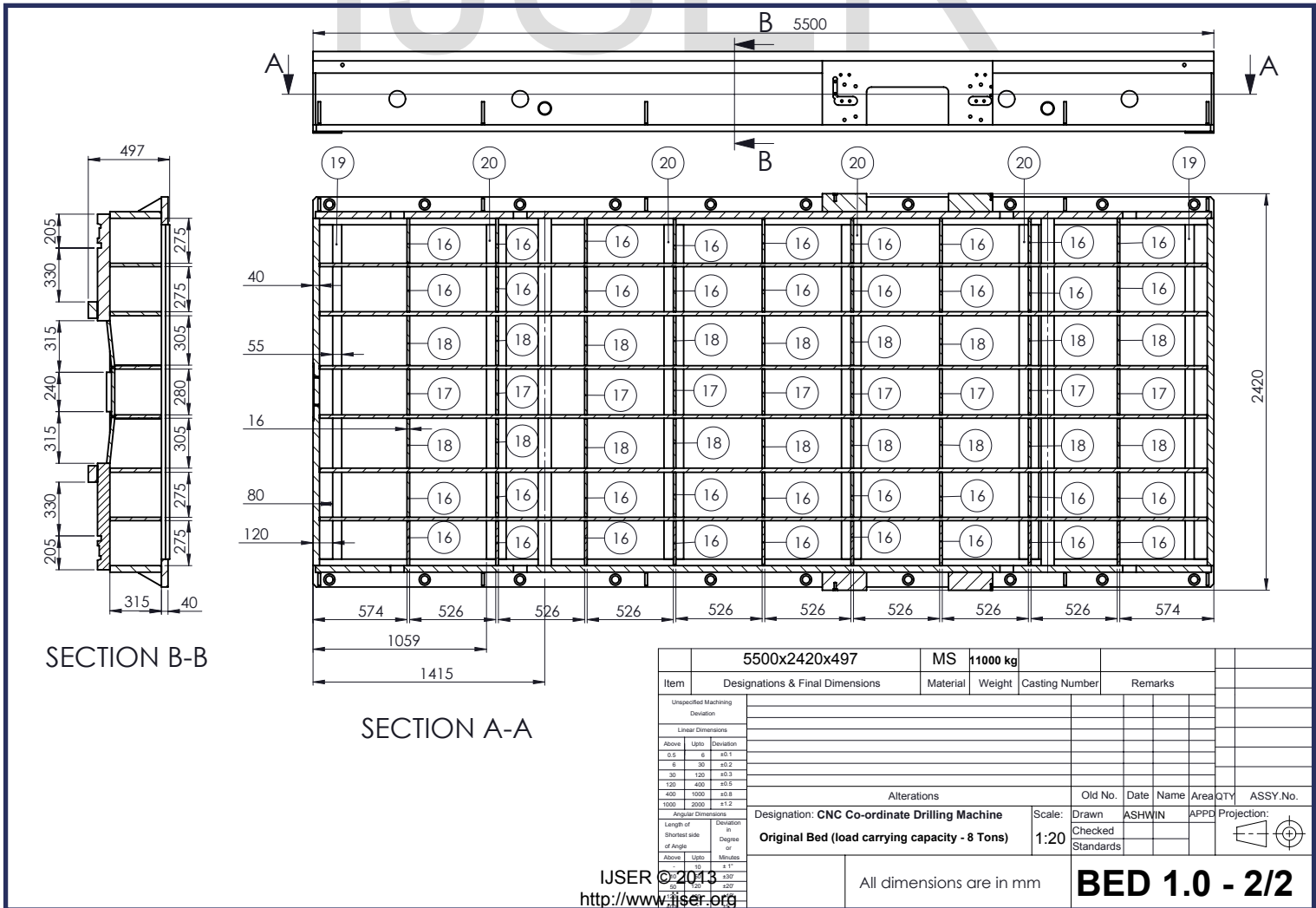

Drawing 3

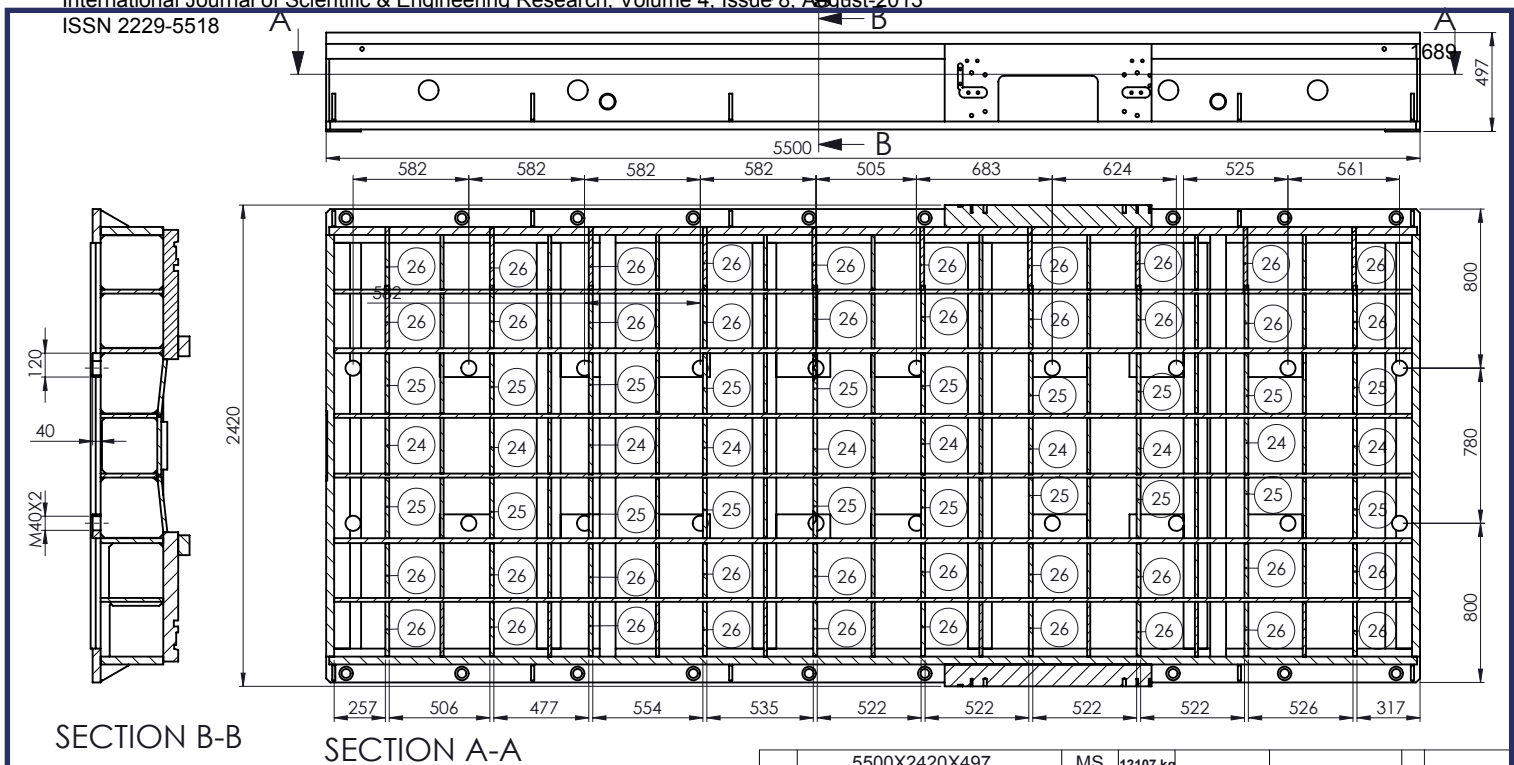

SECTION B-B

SECTION A-A

Total weight of BED 2.0 (redesigned by HMT)

- Weight of Original Bed 1.0 = 11000 kg
 - Weight of additional ribs = 1107 kg
-
- Total weight of BED 2.0 = 12107 kg

5500X2420X497		MS	12107 kg						
Item	Designations & Final Dimensions	Material	Weight	Casting Number	Remarks				
Unspecified Machining Deviation									
Linear Dimensions									
Above	Up to	Deviation							
0.5	6	±0.1							
6	30	±0.2							
30	120	±0.3							
120	400	±0.5							
400	1000	±0.8							
1000	2000	±1.2							
Angular Dimensions									
Length of Shortest side of angle	Deviation in Degree								
Above	Up to	Minutes							
10	±1°								
10	±5'								
50	±10'								
120	±10'								
Alterations				Old No.	Date	Name	Area	QTY	ASSY. No.
Designation: CNC Co-ordinate Drilling Machine				Scale:	Drawn	ASHWIN	APPD	Projection:	
Redesigned by HMT (load carrying capacity-14 ton)				1:19	Checked				
				Standards					
All dimensions are in mm				BED 2.0					

Drawing 4

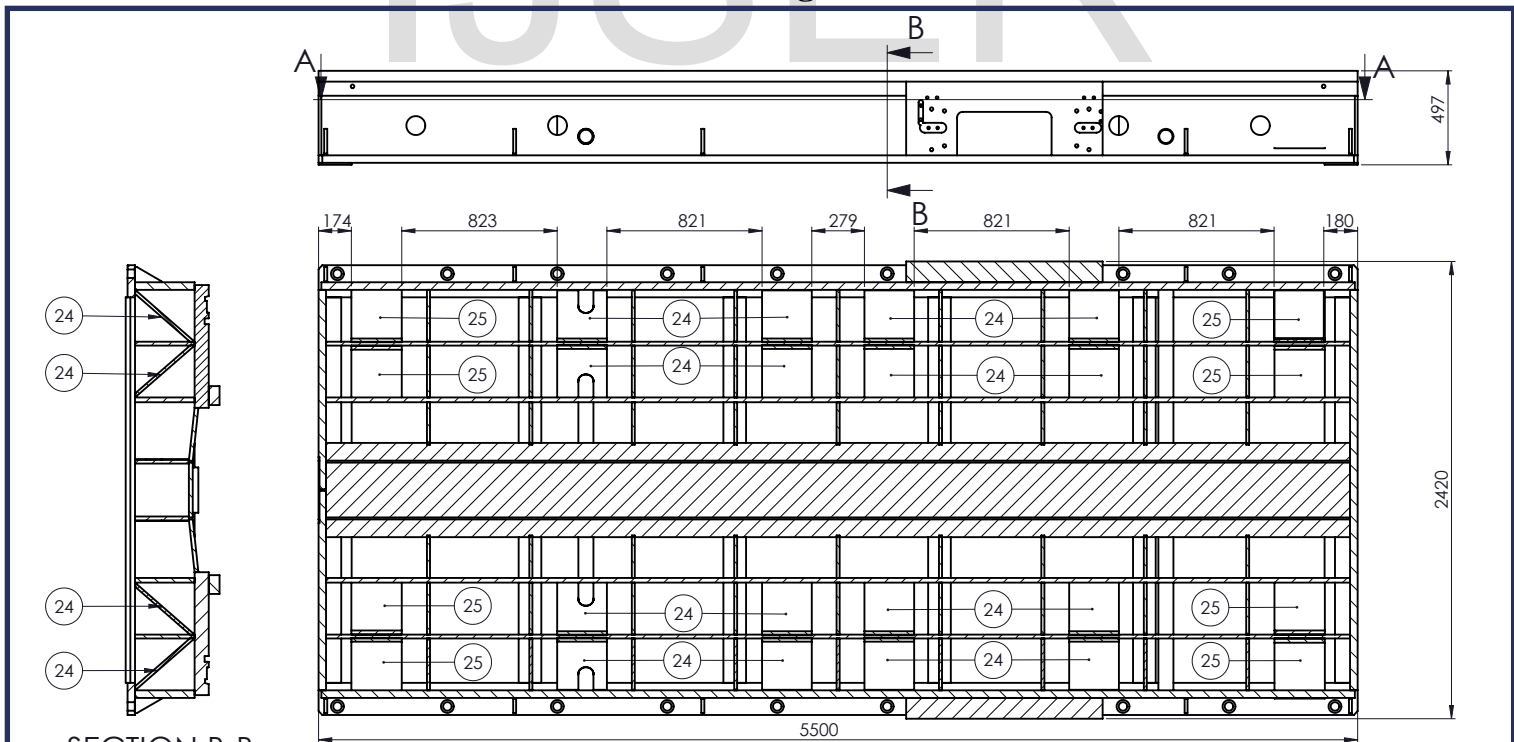

SECTION B-B

SECTION A-A

Total weight of BED 3.0 (Optimized bed design)

- Weight of Original Bed 1.0 = 11000 kg
 - Weight of additional ribs = 320 kg
-
- Total weight of BED 3.0 = 11320 kg

5500X2420X497		MS	11320 kg						
Item	Designations & Final Dimensions	Material	Weight	Casting Number	Remarks				
Unspecified Machining Deviation									
Linear Dimensions									
Above	Up to	Deviation							
0.5	6	±0.1							
6	30	±0.2							
30	120	±0.3							
120	400	±0.5							
400	1000	±0.8							
1000	2000	±1.2							
Angular Dimensions									
Length of Shortest side of angle	Deviation in Degree								
Above	Up to	Minutes							
10	±1°								
10	±5'								
50	±10'								
120	±10'								
Alterations				Old No.	Date	Name	Area	QTY	ASSY. No.
Designation: CNC Co ordinate Drilling Machine				Scale:	Drawn	ASHWIN	APPD	Projection:	
Optimized Bed (load carrying capacity - 14 ton)				1:20	Checked				
				Standards					
All dimensions are in mm				BED 3.0					

3. AUTO CAD DRAWINGS

Solid Works premium 2012 version is used to create the auto CAD 2D drawings of the beds. These drawings represent the orientation of the ribbing pattern and the assembly of plates. The CAD drawings are represented in Drawing 1& 2 (BED 1.0), Drawing 3 (BED 2.0) and Drawing 4 (BED 3.0).

4. RESULTS OF ANALYSIS

4.1 Boundary and Loading Conditions

The boundary and the loading conditions for all 3 beds are the same. This is done in order to attain a clear comparison among the 3 beds. The bounding box geometry of BED 1.0, 2.0 and 3.0 is 5500 x 2420 x 505 mm. The linear motion (LM) guides and the linear motion (LM) blocks are attached to the beds represented in the engineering drawings. All the 3 bed have the minimum edge length for the mesh as 0.145990 mm, with a transit ratio of 0.272.

BED 1.0 has 116 bodies with 366078 nodes and 197379 elements. Due to the additional plates added to the original bed design, BED 2.0 has 202 bodies, which hold 409087 nodes and 203145 elements. BED 3.0 has only 153 bodies with 386375 nodes and 198656 elements. The addition of ribs and alteration of ribbing patters causes variation in the bodies, nodes and elements of the beds.

A point load of 14000 kg was equally distributed on the 8 LM blocks attached to the LM guides as shown in fig 4. As a result a force of (-) 17161 N/mm was applied on each of the LM block. The degree of freedom was arrested in the 10 holes assigned for the foundation bolts. These holes are present in the base plate of the bed. The same loading conditions were applied on all 3 beds. The additional set of leveling screws added to BED 2.0 leaves the degree of freedom arrested for 20 holes in BED 2.0. This gives BED 2.0 additional support in comparison with BED 1.0 and 3.0.

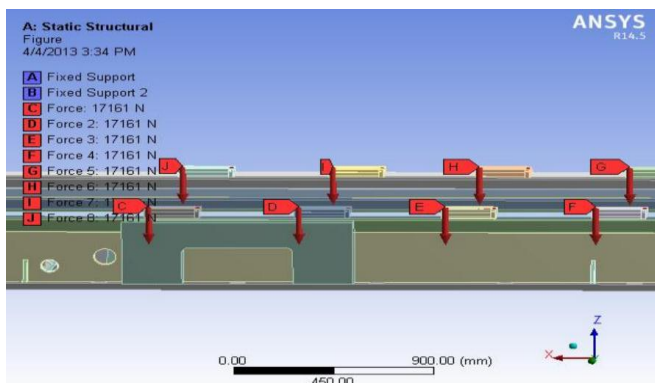

Fig 4: Load Application

4.2 Finite Element Results of BED 1.0

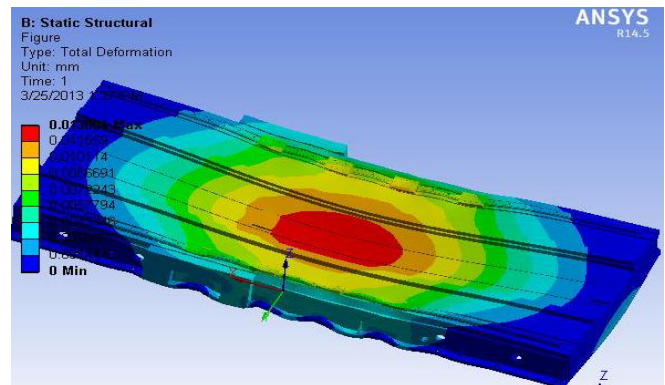

Fig 5: Total Deformation of BED 1.0

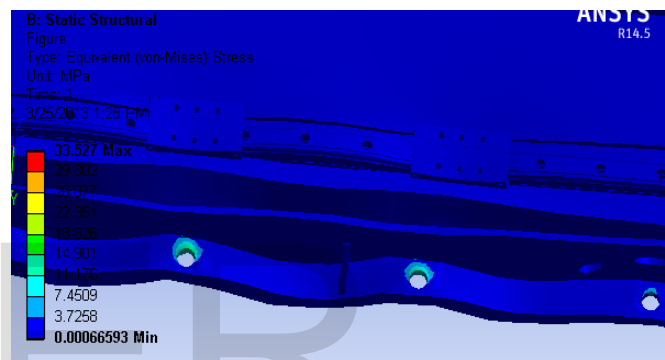

Fig 6: Total Stress of BED 1.0

On applying the load of 14000 kg, BED 1.0 had a maximum deformation of 0.013004 mm. It may be observed from fig 5 that the maximum deformation occurred in the center of the bed. From fig 6 we know that the maximum stress value attained from analysis is 33.527 MPa. The value of maximum stress is well within the yield stress. The new design must incorporate alternating ribbing pattern to provide support at the point where maximum deformation occurs in order to attain lower deformation.

4.3 Finite Element Results of BED 2.0

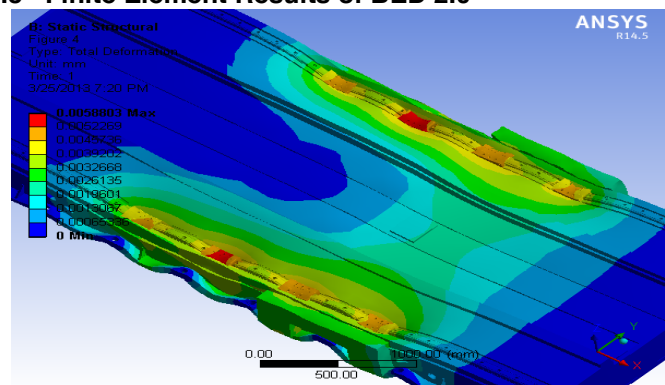

Fig 7: Total Deformation of BED 2.0

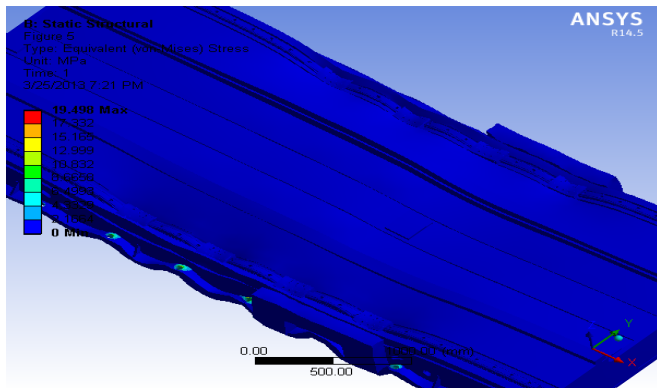

Fig 8: Total Stress of BED 2.0

On applying the load of 14000 kg, BED 2.0 had a maximum deformation of 0.0058803 mm. It may be observed from fig 7 that the maximum deformation occurred in the center of the LM blocks where the force was applied. This is a clear indication that there was enough support required to withstand the force. The reorientation of ribbing pattern by adding about 1107 kg to BED 1.0 led to the change in the deformation pattern from that of BED 1.0.

From fig 8 we know that the maximum stress value attained from analysis is 19.48 MPa. The value of maximum stress is well within the yield stress. This design provides the required support to accomplish very low value of maximum deformation. The maximum stress obtained also is much lesser than that of BED 1.0.

4.4 Finite Element Results of BED 3.0

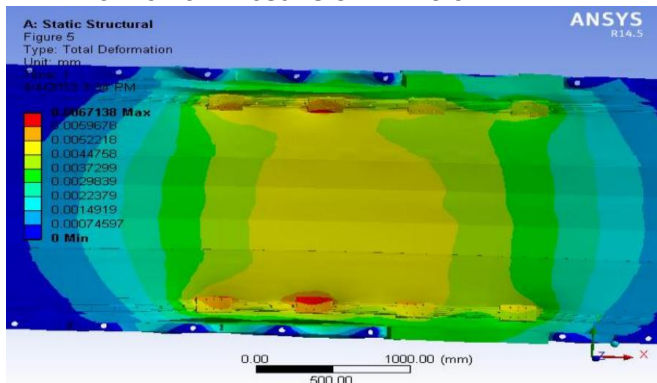

Fig 9: Total Deformation of BED 3.0

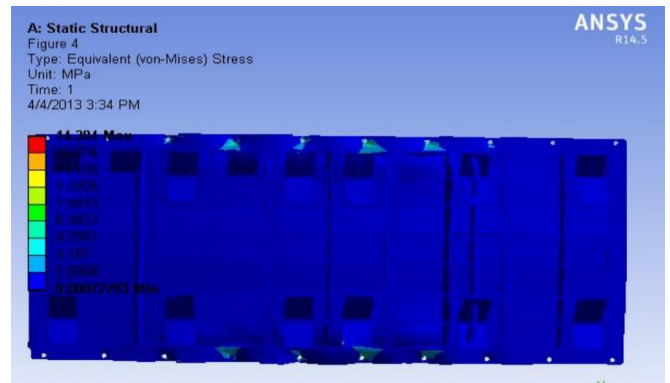

Fig 10: Total Stress of BED 3.0

On applying the load of 14000 kg, BED 3.0 had a maximum deformation of 0.0067138 mm. The deformation pattern observed from fig 9 resembles that of BED 2.0 this is a clear indication that there was enough support required to withstand the applied force. The reorientation of ribbing pattern by adding about 320 kg to BED 1.0 led to the change in the deformation pattern from that of BED 1.0.

From fig 10 we know that the maximum stress value attained from analysis is 14.384 MPa. In this case stress value is 5.11 MPa less than BED 2.0 and well within the yield stress. This design provides the required support to accomplish very low value of maximum deformation. The maximum stress obtained also is much lesser than that of BED 1.0 and BED 2.0.

5. CONCLUSION

5.1 Results and Discussions

Table 2: Results of Analysis

Description	Max Deformation (mm)	Max Stress (MPa)	Weight (kg)	Load Applied (kg)
Original bed BED 1.0	0.013004	33.527	11000	14000
Bed re-designed by HMT BED 2.0	0.0058803	19.498	12107	14000
Optimized bed designed by author BED 3.0	0.0067138	14.384	11320	14000

From table 2 it is very clear that the maximum deformation and the maximum stress occurred in BED 1.0. From fig 5 it is evident that the maximum deformation occurs at the center of the bed. In order to attain minimum deformation it is important to concentrate in the center region and strengthen it with additional support.

Optimization and Enhancement of Load Carrying Capacity of CNC Coordinate Drilling Machine using Finite Element Method

BED 2.0 is designed in such a way such as to overcome the shortcomings of the former. In this design the deformation is not allowed to concentrate in the center because of the additional ribs added and due to the extra lines of leveling screws added on either sides of the central axis of the machine. As a result of the modification's done to the design, there is a considerable reduction in the max deformation and the max stress.

On comparing the results of BED 1.0 and 2.0 it becomes obvious that by providing additional support the deformation is prevented from concentrating at the center, hence minimizing the max deformation and stress. The objective of the analysis is to attain the best possible results with the minimum use of material. The intention is to generate a deformation pattern similar to that of BED 2.0. By implementing the concept of purlin principle, the load is transferred from the LM blocks to the outer structure of the bed; as a result the required results are obtained in BED 3.0.

On considering the results produced by BED 1.0 without the work table and having considering only the static analysis, its maximum deformation is 13 microns and maximum stress is 33.5 MPa whereas the Yield Strength of Mild Steel is 370 MPa. Hence one can conclude that the original bed is capable of withstanding the required load capacity. From the above analysis it is evident that the BED 1.0 is suitable for the prescribed usage of load capacity at lower precision. The maximum allowable deformation for the application of this machine is 20 microns.

To accomplish higher precision, minimum deformation is required. BED 2.0 or BED 3.0 should be chosen upon BED 1.0 to obtain a higher precision during its operation. It may be observed that the weight of BED 2.0 is much higher than BED 3.0 on implementing the optimized bed design approximately 800 kg of Mild Steel can be saved. Which means a sum of about INR 100000 rupees is saved. Not only BED 3.0 is economically more viable, with respect to operation; its max deformation is almost the same as BED 2.0 and its max stress is around 5 MPa lesser than BED 2.0 consequently during full load condition BED 3.0 is more suitable than BED 2.0.

5.2 Scope of Future Work

The finite element analysis (FEA) has been carried out on the bed of the machine. Here, the analysis has considered only the static forces acting on the bed. The dynamic forces have not been taken into consideration. The weight of the work table is 4970 kg an addition of this weight would surely increase the deformation. Hence an analysis is to be carried out with the work table assembled on to the bed as shown in fig 11 for more appropriate results. The 3 models of bed have been analyzed to check/validate if they can withstand required 14000 kg load but their actual capability have not been verified. But

one can conclude BED 3.0 will be appropriate if the additional weight is also considered (Work Table) and in meeting the required accuracy of deformation i.e. maximum of 20 microns.

The scope of future work can be in three possible ways as given below:

1. Carry out analysis with the work table attached to the bed.
2. Consider the dynamic forces acting on the machine components.
3. Identification of the actual load carrying capability of the individual models of bed.

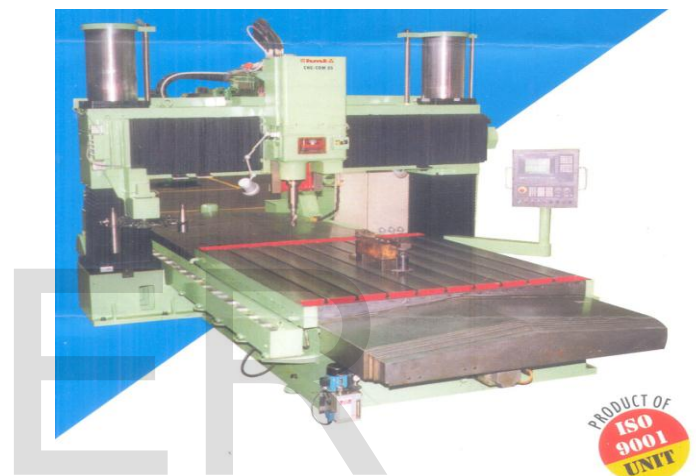

Fig 11: CNC Coordinate drilling machine

REFERENCES

- [1] Basava Raju Pondhe, P.Balasubramanyam and Anil Kumar P. Katti, "Finite Element Structural Analysis on CNC Lathe", part 1- Modelling; NASDYN 98, Finite Element Analysis in Industry-Recent Trends, August 7 1998, IIT Madras.
 - [2] Basava Raju Pondhe, P.Balasubramanyam and Anil Kumar P. Katti, Finite Element Structural Analysis on CNC Lathe, part 2 - Analysis and design; NASDYN 98, Finite Element Analysis in Industry-Recent Trends, August 7 1998, IIT Madras.
 - [3] Prof. Dr. Muhsin J. Jweeg, Asst. Prof. Dr. Shawkat J. AL-Tornachi, Asst. Lect. Salah H. Abid-Aun, Optimization of Light Weight Aircraft Wing Structure, Journal of Engineering and Development, Vol. 12, No. 1, March (2008) ISSN 1813-7822
- Books:
- [4] Innovent Engineering Solutions, ANSYS Structural Mechanics Training Manual
 - [5] Tadeusz Stolarski, Y.Nakasone,S.Yoshimoto, "Engineering Analysis with ANSYS Software"